



Administrative Council for Terminal Attachments (“ACTA”)

Guidelines & Procedures for submittal of information to the ACTA for inclusion in the database of approved Telephone Terminal Equipment

**Revision 3.1
May 2008**

The ACTA is jointly sponsored by the
Alliance for Telecommunications Industry Solutions and the
Telecommunications Industry Association



1200 G Street NW Suite 500 Washington, DC 20005

Phone: 202-628-6380 Fax: 202-393-5453 Web: www.part68.org

December 13, 2006

NOTICE

The ACTA Secretariat has made the following changes to the “Guidelines & Procedures for submittal of information to the ACTA for inclusion in the database of approved Telephone Terminal Equipment” to result in version 3.0 of this document. This document supersedes all previous versions.

- Revision to Section 4.2 to provide clarification for the need to include citation on TCB certificates to ACTA Adopted Technical Criteria after the “Effective” date and prior to the “Mandatory” Date.
- Revision to Section 5.2 to provide clarification for the need to include citation on a Suppliers Declaration of Conformity (SDoC) to ACTA Adopted Technical Criteria after the “Effective” date and prior to the “Mandatory” Date.
- Inclusion of the Telephone Terminal Equipment Submission Form Ver. 1.06 as an informative appendix.
- Inclusion of a new Responsible Party Code Form Ver. 1.0, for submitting requests for RPC codes, updating RPC information, and transfer of RPC as an informative appendix.

TABLE OF CONTENTS

1	INTRODUCTION	6
2	MISSION & SCOPE	7
	2.1 MISSION OF THE ACTA	7
	2.2 SCOPE OF THE SUBMISSION GUIDELINES	7
	2.3 NOTICE OF FCC PART 68 COMPLIANCE REQUIREMENT FOR TERMINAL EQUIPMENT	7
	2.4 DESCRIPTION OF TERMINAL EQUIPMENT SUBJECT TO SUBMISSION TO THE ACTA DATABASE.....	7
3	GENERAL FILING GUIDELINES	9
	3.2 FILING FOR A RESPONSIBLE PARTY CODE	10
	3.3 CHANGES IN NAME, ADDRESS, OWNERSHIP OR CONTROL OF RESPONSIBLE PARTY:.....	11
	3.4 ACTA ONLINE FILING (“AOF”) SYSTEM	13
4	TELECOMMUNICATIONS CERTIFICATION BODY FILINGS	16
	4.1 BACKGROUND	16
	4.2 FILING UTILIZING TCBS.....	16
5	SUPPLIER’S DECLARATION OF CONFORMITY FILINGS	18
	5.1 DEFINITION.....	18
	5.2 SDOc CONTENT	18
	5.3 FILING UTILIZING SDOcS	18
	5.4 SDOc POSTING ON THE ACTA WEBSITE.....	19
6	GENERAL REQUIREMENTS.....	20
	6.1 INDEMNIFICATION AND LIABILITY STATEMENTS.....	20
	6.2 CONSUMER INFORMATION	21
	6.3 FCC ISSUED WAIVERS	21
	APPENDIX A: TERMINAL EQUIPMENT DETAILS (NORMATIVE)	23
	DEFINITION OF TERMINAL EQUIPMENT DETAIL ITEMS:	24
	<i>Item 1a: Name of Organization Granting Approval of Equipment or Submitting Request for RPC.....</i>	<i>24</i>
	<i>Item 1b: Telecommunications Certification Body Identification Number.....</i>	<i>24</i>
	<i>Item 1c: Supplier’s Declaration of Conformity</i>	<i>24</i>
	<i>Item 2: Terminal Equipment Approval Date</i>	<i>24</i>
	<i>Item 3: Product Identifier</i>	<i>24</i>
	<i>Item 4: Responsible Party.....</i>	<i>24</i>
	<i>Item 5: Agent for Service</i>	<i>25</i>
	<i>Item 6: Equipment Description.....</i>	<i>25</i>
	<i>Item 7: Responsible Party Code (“RPC”).....</i>	<i>25</i>
	<i>Item 8: Manufacturer Code</i>	<i>25</i>
	<i>Item 9: Current ACTA or FCC Product Label Number</i>	<i>25</i>
	<i>Item 10: Equipment Code</i>	<i>25</i>
	<i>Item 11a: List of Brand or Trade Names including new & existing Names.....</i>	<i>25</i>

Guidelines & Procedures for Submittal of Information to the ACTA for Inclusion in the Database of Approved Telephone Terminal Equipment

Item 11b: List of Model Numbers including new & existing Brand or Trade Names 25

Item 12: Network Address Signaling Code..... 26

Item 13a: AC Ringer Equivalence Number (“REN”)..... 26

Item 13b: Hearing Aid Compatible (“HAC”) 26

Item 13c: Universal Service Order Codes (“USOC”) Jacks..... 26

Item 13d: Repetitive Dialing to a Single Number..... 26

Item 14: Filing Status..... 26

Item 15: Facility Interface Codes (“FIC”)..... 28

Item 16: Manufacturer Port ID..... 30

Item 17 & 18: Service Order Codes (“SOC”) and Answer Supervision Codes..... 30

Item 19: Ancillary Equipment..... 31

APPENDIX B: INDEMNIFICATION AND LIABILITY STATEMENT (NORMATIVE)32

APPENDIX C: AOF INDEMNIFICATION AND LIABILITY STATEMENT (NORMATIVE) 34

APPENDIX D: EXAMPLE LANGUAGE FOR AN SDOC (NORMATIVE) 36

APPENDIX E: CONSUMER INFORMATION (INORMATIVE) 38

CUSTOMER INFORMATION: 38

GENERAL REQUIREMENTS FOR ALL EQUIPMENT: 39

CUSTOMER-OWNED COIN/CREDIT CARD PHONES: 41

DATA EQUIPMENT: 41

PRIVATE (LEASED) LINES FOR ANALOG SERVICES: 41

SYSTEMS: 42

ADJUNCTS - KX AND PX DEVICES: 42

OEM DEVICES: 42

AUTOMATIC DIALERS: 43

TOLL RESTRICTION AND LEAST COST ROUTING EQUIPMENT: 43

EQUIPMENT WITH DIRECT INWARD DIALING (“DID”): 43

EQUAL ACCESS REQUIREMENTS: 44

ELECTRICAL SAFETY ADVISORY: 44

EQUIPMENT WITH FAX CAPABILITY: 44

ALARM DIALING EQUIPMENT: 45

TYPE Z RINGER INFORMATION 47

APPENDIX F: TTE SUBMISSION FORM (INFORMATIVE)..... 48

APPENDIX G: RESPONSIBLE PARTY CODE FORM (INFORMATIVE)..... 51

APPENDIX H: CREDIT CARD PAYMENT FORM (INFORMATIVE)..... 52

Guidelines & Procedures for Submittal of Information to the ACTA for Inclusion in the Database of Approved Telephone Terminal Equipment

Commonly used Acronyms

Acronym	Definition
ACTA	Administrative Council for Terminal Attachments
ANSI	American National Standards Institute
AOF	ACTA Online Filing
ATIS	Alliance for Telecommunications Industry Solutions
DTMF	Dual Tone Multi-Frequency
FCC	Federal Communication Commission
FIC	Facility Interface Code
HAC	Hearing Aid Compatibility
MRAs	Mutual Recognition Agreements/Arrangements
NIST	National Institute of Standards and Technology
OP&P	Operating Principles & Procedures
PSTN	Public Switched Telephone Network
R&O	Report & Order
RJ31 or RJ31X	Type of jack that deals with alarm dialers
RP	Responsible Party
RPC	Responsible Party Code
SDO	Standards Developing Organization
SDoC	Supplier's Declaration of Conformity
TCB	Telecommunications Certification Body
TIA	Telecommunications Industry Association
TTE	Telephone Terminal Equipment
USOC	Universal Service Order Codes

1 Introduction

The Administrative Council for Terminal Attachment (“ACTA”) was established pursuant to the Federal Communication Commission’s (“FCC”) Report and Order in the 2000 Biennial Review of Part 68 of the Commission’s Rules and Regulations, CC Docket No. 99-216, FCC 00-400, adopted November 9, 2000 and released December 21, 2000 (“Order” or “R&O”). The Order directed the industry, through the co-sponsorship and support of the Telecommunications Industry Association (“TIA”) and the Alliance for Telecommunications Industry Solutions (“ATIS”) to establish the ACTA as the balanced and open body that would assume the Commission’s Part 68 role for those items privatized in the Order (§68.602).

2 Mission & Scope

2.1 Mission of the ACTA

The mission of the ACTA is to: (1) adopt technical criteria for terminal equipment to prevent network harm through the act of publishing such criteria developed by the American National Standards Institute (“ANSI”)-accredited standards development organizations; and (2) establish and maintain database(s) of equipment approved as compliant with the technical criteria. The ACTA makes no substantive decisions regarding the content of such technical criteria.

2.2 Scope of the Submission Guidelines

This document outlines the guidelines and procedures relevant to maintaining a database(s) of terminal equipment approved as compliant to FCC Part 68 and ACTA-adopted technical criteria. These guidelines and procedures apply to information submitted by both Telecommunications Certification Bodies (“TCB”) and suppliers utilizing a Supplier’s Declaration of Conformity (“SDoC”).

Pursuant to §68.610(b), Responsible Parties, whether they obtain their approval from a Telecommunications Certification Body or utilized the Supplier’s Declaration of Conformity process, shall submit to the ACTA Secretariat all information required by the Administrative Council for Terminal Attachments.

2.3 Notice of FCC Part 68 Compliance Requirement for Terminal Equipment

Compliance with Part 68 and ACTA Adopted Technical Criteria is mandatory for terminal equipment (TE) connected to the Public Switched Telephone Network (PSTN) or wireline facilities owned by wireline telecommunications providers and used to provide wireline subscriber services. Penalties for failure to comply with the requirement fall under US federal jurisdiction. Penalties can be found in 47 U.S.C. Section 503.

Questions about the compliance requirements for a particular device should be addressed to a TCB with Scope C certification (or other CAB). More information on finding Scope C certified testing bodies can be found on the ACTA and FCC websites. Questions about a specific technical requirement should be addressed to the standards development organization from which the technical requirement was submitted to the ACTA.

2.4 Description of Terminal Equipment Subject to Submission to the ACTA Database

This is an informative description of terminal equipment subject to submission to the ACTA Database provided to inform the public of the scope of devices subject to the ACTA’s adopted technical criteria and database and is not in any way intended to serve as a qualitative analysis of any device. The controlling document for determining the

Guidelines & Procedures for Submittal of Information to the ACTA for Inclusion in the Database of Approved Telephone Terminal Equipment

need for equipment compliance is the United States Code of Federal Regulations, Title 47, Part 68 (47 CFR 68).

For ACTA Part 68 Database purposes, terminal equipment that requires formal Approvals testing for “do not harm” requirements and has provision and requirement for listing in the ACTA Part 68 Database is any communication equipment located on a customer’s premise at the end of a communications link as provided in 47 CFR 68, used to permit the TE involved to accomplish the provision of telecommunication or information services including but not limited to:

1. Single-line or Multi-line Telephones;
2. Modems (any device that is or contains an analog, digital or Ethernet modem used as an interface to the network);
3. Facsimile Machines;
4. xDSL Modems (ex. ADSL, HDSL, VDSL & GDSL) ;
5. DSL Splitters & Filters;
6. Voltage Transient Protective devices;
7. Electronically Controlled Line Switches, Indicators and Devices;
8. Private Branch Exchanges (PBXs);
9. Key Telephone System (KTS) equipment;
10. Local Area Network (LAN) Gateways to the PSTN;
11. Caller Identification (CID) devices;
12. Music on hold devices;
13. Interactive Voice System (ACD or IVR);
14. CSUs;
15. Answering Machines; and
16. Any remote control or Utility Metering or Alarm System device that connects to the PSTN.

The following items do not require formal approval or listing in the ACTA Part 68 Database and no provision has been made for listing such items in the ACTA Part 68 Database:

1. Electronically transparent adapters and extension cords;
2. Cross connect panels;
3. Manually operated line switches; and
4. Professionally used diagnostic instrumentation that is disconnected from the network when unattended.

3 General Filing Guidelines

Parties submitting information to the ACTA for inclusion in the centralized database of approved Part 68 Terminal Equipment (“TE”) should file submissions using the ACTA Online Filing (“AOF”) system. Filing types currently supported by AOF are Original, Modification, Notice of Change, Re-certification and Request for RPC. Filing types not specified must be submitted, by postal mail or E-mail, to the ACTA Secretariat. Unless otherwise noted, documents requested should be submitted in Adobe (PDF) format. Filings not submitted in the format requested could delay the processing procedure.

3.1 Filing Fees and Payment

A fee for recording, updating, and maintaining information/content in the ACTA Database is required. The basic fee for all filings is \$425 (US). An additional \$95(US) handling fee is required for Original, Modification and Notice of Change filings that are submitted directly to the ACTA Secretariat for processing. Fees for filings submitted directly to the ACTA Secretariat can be made by check payable to ATIS/ACTA Secretariat, or by credit card using the “Credit Card Payment Form” in Appendix F. Fees for filings submitted utilizing AOF must be paid via credit card.

The following provides a breakdown in associated filing fees. Parties are encouraged to visit the ACTA website at <http://www.part68.org> for updates or revisions to the appropriate Filing fee. Questions about the filing process or filing fees should be directed to AOFquestions@atis.org.

Fees associated with Filings submitted to the ACTA Secretariat		
Item	Fee	Applicability
Original, Modification & Notice of Change Filing Fee	\$425.00	This fee is required for recording, updating, and maintaining TE information.
Transfer of RPC Filing	\$425.00	This fee is required for the transfer of control or ownership of a Responsible Party Code between two parties.
SDoC Posting	\$425.00	This fee is required for making a Responsible Party’s Supplier’s Declaration of Conformity publicly accessible on the ACTA website. See Section 5.4 for applicability.
Handling Fee	\$95.00	This fee is required for handling filing types that are supported by AOF but submitted to the ACTA Secretariat for processing. The fee is per TE Form submitted.

Guidelines & Procedures for Submittal of Information to the ACTA for Inclusion in the Database of Approved Telephone Terminal Equipment

Fees associated with Filings submitted using AOF		
Original, Modification & Notice of Change Filing Fee	\$425.00	This fee is required for recording, updating, and maintaining information.
SDoC Posting	\$425.00	This fee is required for making a Responsible Party's Supplier's Declaration of Conformity publicly accessible on the ACTA website. See Section 5.4 for applicability.
AOF Corrections	\$95.00	This fee is for making administrative changes to the Part 68 database to correct AOF Filing errors, misspellings, updates, etc that are made by the Secretariat. Request for AOF corrections must be submitted to the ACTA Secretariat directly.
Audit Corrections	TBD	This fee is for making changes to a filing that has been returned for errors during the audit process. These changes are made by the filer and should be made within 15 days of the return notice at no charge. Failure to correct a filing during this period will prevent the submission from being included in the ACTA database and fees for corrections may be incurred.

Filings sent by postal mail should be sent to:

ATIS
Attention: ACTA Secretariat
1200 G Street N.W., Suite 500
Washington, DC 20005

Filings sent by E-mail should be sent to AOFquestions@atis.org.

3.2 Filing for a Responsible Party Code

The ACTA-specified Responsible Party Code (“RPC”) is a unique identifier assigned to the Party responsible for terminal equipment. Historically, the FCC Common Carrier Bureau (“CCB”), now called the “Wireline Competition Bureau,” referred to this code as an Applicant or Grantee Code¹. Codes previously assigned by the FCC CCB, therefore, remain valid and, unless otherwise warranted, may continue to be used. A new RPC is needed:

- When the Responsible Party does not have an RPC or FCC Common Carrier

¹ Note that both the FCC CCB (in charge of TE) and the FCC Office of Engineering Technology (“OET”), for RF Devices, issued Grantee Codes. The codes issued were identical in format, but maintained in separate lists. Only those Grantee Codes assigned by the CCB are valid as RPCs.

Guidelines & Procedures for Submittal of Information to the ACTA for Inclusion in the Database of Approved Telephone Terminal Equipment

- Bureau Grantee Code.
- When it is required for a partial transfer of ownership (see 3.2).

The Responsible Party or its Authorized Submitter (*e.g.*, a TCB or independent lab) must provide the following information and items from Appendix A, Terminal Equipment Details, when requesting an RPC. If applicable, an RPC must be obtained by the Responsible Party before its first Filing:

- Item 1a): Name of Organization Granting Approval or Submitting Request for RPC: To be completed by the Authorized Submitter requesting a RPC for the Responsible Party, if applicable. To expedite requests, an E-mail address should be provided, as the RPC will be sent by Electronic Mail² (*e.g.*, E-mail).
- Item 4): Responsible Party: Information relevant to the Responsible Party must be provided. To expedite requests, an E-mail address should be provided, as the RPC will be sent by Electronic Mail (*e.g.*, E-mail).
- Item 7): Responsible Party Code: A specific RPC may be requested. The requested RPC will be assigned if available.
- Item 14): Filing Status: Insert “Request for RPC.”

Requests for a RPC can be submitted through AOF, or by submission to the ACTA Secretariat using the TE Submission Form. The fee for a RPC Filing via AOF is \$425 (US).

3.3 Changes in Name, Address, Ownership or control of Responsible Party:

Responsible Party Codes are assigned to Parties responsible for terminal equipment. Accordingly, multiple Parties cannot use the same RPC.

As specified in §68.322, Responsible Parties for an SDoC may license or otherwise authorize a second party to manufacturer the terminal equipment covered by the SDoC provided the Responsible Party retains sole responsibility for ensuring the equipment remains compliant with the relevant FCC rules and ACTA-adopted technical criteria.

In the case transactions affecting the identification of the Responsible Party of an SDoC, such as a transfer of control or sale to another company, mergers, or transfer of manufacturing rights, the successor entity shall become the responsible party. Note: this statement is also true for Responsible Parties using the TCB process.

For example, in the event a party transfers complete control (*i.e.*, ownership) of its operations to another entity (the “successor”), the original party may transfer its RPC to the successor provided the original party discontinues use and reference of its assigned RPC. Alternatively, a new RPC can be assigned to the successor in accordance with Section 3.1. Use of a new RPC requires a Re-approval notice and, therefore, reformatting

² Note; the ACTA Secretariat will issue a RPC via E-mail to the Authorized Submitter and/or Responsible Party typically within 7-10 days. Contact the ACTA Secretariat if an E-mail is not received. An alternative method (*e.g.*, regular mail) is available on request.

Guidelines & Procedures for Submittal of Information to the ACTA for Inclusion in the Database of Approved Telephone Terminal Equipment

of the equipment's identification number to reflect the ACTA Product-Labeling format, if applicable.

Parties filing a request to transfer a RPC must file notice with the ACTA in accordance with Section 3, General Filing Guidelines. Notification shall include:

- 1) A letter from the original Responsible Party (on company letterhead) informing the ACTA as to the type and extent of transfer of control to the successor.
- 2) Appendix A, where:
 - Item 4): Responsible Party. Detail the new Responsible Party. To expedite requests, an E-mail address should be provided as confirmation will be sent by Electronic Mail (*e.g.*, E-mail).
 - Item 5) US Agent of Service: The new Responsible Party shall provide the ACTA with the current US Agent of Service for all registered TE, including legacy Filings for which a US Agent of Service may not currently be provided.
 - Item 7): Responsible Party Code: Identify the RPC being transferred from the original Responsible Party to its successor.
 - Item 9): Current Authorization Number: List of all products to be transferred by their current Authorization Number.
 - Item 14): Filing Status: Indicate "Request for RPC Transfer."
- 3) Revised SDoC (for SDoC Filings only):

The new Responsible Party shall provide the ACTA with a copy of updated/revised SDoCs reflecting the name of the new Responsible Party on the SDoC for those products they continue to market. If a RP wishes to provide updated/revised SDoCs for additional products, this also may be done during the transfer on a voluntary basis.

In the event a party transfers "partial" control (*i.e.*, responsibility) of its operations or transfers a product or product-line to another entity (the "successor"), a Re-approval notice shall be filed with the ACTA for each product transferred. Notification(s) shall include a letter from the original Responsible Party (on company letterhead) informing the ACTA of the transfer in addition to all items specified for an Original Filing. Re-approval Filings shall be made by the successor.

In the event a Responsible Party grants another party or parties (*i.e.*, 3rd party) rights to re-label an Part 68 approved product under the 3rd party's Responsible Party Code (for marketing reasons) and distribute that product in addition to the original Responsible Party maintaining its distribution of the same product, a Re-approval notice shall be filed with the ACTA for each product effected. Notification(s) shall include a letter from the original Responsible Party (on company letterhead) informing the ACTA of the agreement and separate distribution of the product in addition to all items specified for an Original Filing. Filings will be presented as an "Original" submission in the ACTA database of approved Part 68 products. *The 3rd party shall submit the Re-approval Filing.*

When responsibilities are transferred from one party to another, the "new" Responsible Party is required to ensure the SDoC(s) for product(s) they continue to produce and market is/are updated to reflect the correct identification of the party responsible for the product. This requirement is applicable for Responsible Parties that assume responsibility for products approved utilizing the SDoC approach only. Parties assuming responsibility for products approved via a TCB are not required to submit a revised TCB certificate, given that parties are not required by the FCC to provide this information to the consumer. However, if/when an RP modifies a product after the transfer, a revised/updated TCB certificate or SDoC must reflect the new company name.

Pursuant to §68.324, Responsible Parties assuming responsibility for products approved utilizing the SDoC process also assumed responsibility for maintaining a copy of the original and any revised/updated SDoCs on their website for ALL the products they assumed responsibility for; regardless if the product is still being produced or not. Should the new Responsible Party inform the ACTA that a copy of the SDoC is not available to the general public and accessible to the disabled community on a functional and reliable website that it maintains, and needs the ACTA to maintain a copy of the original or revised/updated SDoC on the ACTA website, the new RP will be charged an additional posting fee per SDoC, pursuant to the ACTA Guidelines.

Parties unfamiliar with RPC transfers should contact the ACTA Secretariat before filing a RPC transfer request.

3.4 ACTA Online Filing (“AOF”) System

The ACTA Online Filing (“AOF”) system is provided for parties to electronically file TE information to the ACTA for inclusion in the centralized database of approved Part 68 terminal equipment. Parties wishing to use AOF must establish a “Filer Account” and obtain a Username and Password to gain access.

The level of access to AOF will hinge on a party’s filing classification (specified below). TCBs using AOF to submit TE information, and its associated Certificate, will have access to all the RPCs, and their corresponding records, on file with the ACTA. Due to this level of access, TCBs are required to authenticate their standing as a recognized TCB before access to AOF is granted. Accordingly, TCBs must always contact the ACTA Secretariat to establish a Filer Account.

Responsible Parties using the SDoC method will have access to their respective RPC, or RPCs only. Agents filing for multiple RPCs though the SDoC method will be able to establish a single Filer Account in order to file for each RPC.

In all cases, all users of the AOF are expected to be familiar with these Submission Guidelines & Procedures. Knowledge of telecommunications and Part 68-specific terminology is also expected.

Guidelines & Procedures for Submittal of Information to the ACTA for Inclusion in the Database of Approved Telephone Terminal Equipment

Once a Filer Account has been established, and a Responsible Party's test plan or test procedures on file with the ACTA Secretariat (if applicable), parties can "login" to AOF and electronically file TE information to the ACTA-maintained database.

Filing types supported by AOF are Original (or New Filing), Modifications, Notice of Change, Re-approvals or Re-certification, and Request for Responsible Party Codes ("RPC"). Filing types not currently supported are Transfer of Control or Ownership of an RPC (as specified in Section 3.2), Blanket Modifications, and Administrative change requests. These filing types must be sent directly to the ACTA Secretariat for entry into the database. No additional handling fee is required for filings types not supported by AOF.

During the AOF process, parties submitting information will be required to acknowledge that the information submitted is accurate, complete, and descriptive of the TE approved for connection to the telephone network. Parties must also acknowledge that submitted information is subject to a 30-day administrative audit by the ACTA or its Secretariat and that the submitting party is responsible for correcting any errors identified within 15-days of notice from the Secretariat. Failure to correct errors identified by the Secretariat in the allotted timeframe could result in the removal of the record from the database and forfeiture of the processing fee. Note: An additional processing fee, beyond the fees specified in Section 3, may be required should a submission compromise the accuracy of the Part 68 database.

AOF classifies parties filing with the Administrative Council into three categories:

(1) SDoC: Authorized Filer for Responsible Parties utilizing the SDoC method

Description: An Authorized Submitter, or Filer, under this classification is **directly** associated with a Responsible Party and submits terminal equipment information under the SDoC method to the Administrative Council. This classification also applies to Responsible Parties that wish to personally submit terminal equipment information that obtained certification from a TCB. Should this happen, the Filer would be required to "upload" the TCB Certificate instead of the SDoC statement when prompted. Also, under this classification, only one RPC per Filer Account is permitted, and Responsible Parties must provide assurance that an electronic copy of its test plan, or test procedure, is on file with the ACTA Secretariat. Note that all new Filer Accounts are created under this classification.

(2) TCB: Authorized Filer for a Telecommunications Certification Body

Description: An Authorized Submitter, or Filer, under this classification is a TCB that submits terminal equipment information, along with a TCB Certificate, to the Administrative Council. Under this classification, the Filer has access to all the RPC's and their corresponding records contained in the database.

Guidelines & Procedures for Submittal of Information to the ACTA for Inclusion in the Database of Approved Telephone Terminal Equipment

(3) Agent: Authorized Filer on behalf of a Responsible Parties utilizing the SDoC method

Description: An Authorized Submitter, or Filer, under this classification is ***indirectly*** associated (*e.g.*, external laboratory or consultant) with a Responsible Party and submits terminal equipment information under the SDoC method to the Administrative Council on behalf of the Responsible Party. Under this classification, the Filer must use the Responsible Party's Filer Account to access AOF. See SDoC: Authorized Filer for Responsible Parties utilizing the SDoC method.

4 Telecommunications Certification Body Filings

4.1 Background

In 1998, the FCC adopted procedures whereby terminal equipment suppliers may submit their products to private Telecommunications Certification Bodies for terminal equipment certification³. The TCB program was designed in connection with Mutual Recognition Agreements/Arrangements (“MRAs”) between the United States and the European Union (“EU”), and the Asia-Pacific Economic Cooperation (“APEC”). The objective of the MRA is to facilitate market access and competition in the provision of telecommunications products that require testing and/or approval.

TCBs satisfying specific qualification criteria may certify equipment. Questions regarding the TCB program should be directed to the TCB Council. Questions regarding a TCB’s test methodologies, procedures, or application, should be directed to that TCB. A current listing of TCBs is available from the ACTA website at <http://www.part68.org/TechInquiries.aspx>.

4.2 Filing Utilizing TCBs

TCBs must provide the following information to the ACTA for all types of filings (*i.e.*, Original, Modification, Notice of Change, or Re-approval) to allow input to the database of approved equipment maintained by the ACTA:

- 1) **Fee:** Refer to “General Filing Guidelines.”
- 2) **Copy of Certification:** A copy of the certification granted to the Responsible Party by the TCB must be submitted with each filing. Certificates are required to include a statement that terminal equipment conforms to (1) each specific ACTA-adopted technical criteria document, including addendums, that has reached its mandatory compliance date at the time of the approval of the TTE, and (2) the requirements found in FCC 47 CFR Part 68. Technical criteria which have been adopted by the ACTA and have reached their effective date may be included on the TCB Certificate at the discretion of the TCB as they are able to certify compliance to those technical criteria. Also refer to Section 6.3, FCC Issued Waivers, if applicable.
- 3) **Product Information:** All relevant information specified in Appendix A: Terminal Equipment Details must be provided. The extent of information submitted will depend on the type of filing (*i.e.*, Original, Re-certification, Modification, etc.).
- 4) **List of Authorized Submitters:** Unless previously submitted and on file, a list of personnel authorized to file on behalf of the TCB must be provided. Information must include Company Name, Address, Phone Number, Name and E-mail address for each individual listed. Additionally, at least one (maximum of three) individual(s) must be identified as a “Primary Contact.” Primary

³ MRA Order, 13 FCC Rcd at 24693, ¶14.

Guidelines & Procedures for Submittal of Information to the ACTA for Inclusion in the Database of Approved Telephone Terminal Equipment

- Contact(s) will be copied on all confirmation notices issued by the ACTA Secretariat, and serve as the company representative(s) for ACTA issues.
- 5) **Indemnification and Liability Statement:** For all filing types submitted to the ACTA Secretariat for inclusion in the database of Part 68 products, a statement must be included (from the responsible party) with each filing. Refer to Appendix B, Indemnification and Liability Statement. Also refer to Section 6.1, Indemnification and Liability Statements.

The ACTA Secretariat will issue a confirmation notice via E-mail to the TCB and/or Responsible Party (if applicable) typically within 7-10 days for Filings sent to the Secretariat. Contact the ACTA Secretariat if an E-mail is not received. An alternative method (*e.g.*, regular mail) is available on request. Incomplete or incorrect submissions will not be entered into the database until completed and/or corrected.

5 Supplier's Declaration of Conformity Filings

5.1 Definition

A Supplier's Declaration of Conformity ("SDoC") is a procedure where the responsible party takes steps necessary to ensure that the terminal equipment complies with FCC 47 CFR Part 68 and ACTA-adopted technical criteria.

5.2 SDoC Content

As specified in §68.324, the SDoC must, at a minimum, include the following information:

- 1) The identification and description of: (a) the responsible party for the SDoC; and (b) the product; including the model number of the product.
- 2) Statements are required to include a statement that terminal equipment conforms to (1) each specific ACTA-adopted technical criteria document, including addendums, that has reached its mandatory compliance date at the time of the approval of the TTE, and (2) the requirements found in FCC 47 CFR Part 68. Technical criteria which have been adopted by the ACTA and have reached their effective date may be included on the SDoC at the discretion of the Supplier as they are able to certify compliance to those technical criteria.
- 3) Date and place of issue of the declaration.
- 4) Signature, name and function of person making declaration.
- 5) A statement that the product, if it incorporates a handset, does or does not comply with §68.316 of the FCC Rules defining Hearing-Aid Compatible ("HAC") terminal equipment.
- 6) For a telephone that is not HAC, as defined in §68.316, the responsible party shall provide the following in the SDoC: (a) notice that FCC rules prohibit the use of that handset in certain locations; and (b) a list of such locations (see §68.112).

Note that for equipment designed to operate in conjunction with other equipment, the characteristics of which can affect compliance of such device with Part 68, and/or ACTA-adopted technical criteria, then the Model Number(s) of such equipment shall be supplied, and such other equipment must also include an SDoC or TCB grant of certification.

5.3 Filing Utilizing SDoCs

Responsible Parties utilizing an SDoC must provide the following information for all filings to the ACTA:

- 1) **Fee:** Refer to "General Filing Guidelines" and "SDoC Posting on the ACTA Website."
- 2) **Copy of SDoC:** An SDoC must contain the statements and information as specified in §68.324; including an explicit reference to the ACTA-adopted

Guidelines & Procedures for Submittal of Information to the ACTA for Inclusion in the Database of Approved Telephone Terminal Equipment

- technical criteria. Also refer to Section 6.3, FCC Issued Waivers, if applicable. Refer to Appendix C, Example Language for an SDoC. SDoCs must be provided in a format accessible to persons with disabilities.
- 3) **Product Information:** All relevant information specified in Appendix A: Terminal Equipment Details must be submitted. The amount of information provided will depend on the type of filing (*i.e.*, Original, Re-certification, Modification, etc.).
 - 4) **Indemnification and Liability Statement:** For all filing types submitted to the ACTA Secretariat for inclusion in the database of Part 68 products, a statement must be provided with each filing. Refer to Appendix B, Indemnification and Liability Statement. Also refer to Section 6.1, Indemnification and Liability Statements.
 - 5) **List of Authorized Submitters:** Unless previously submitted and on file, a list of personnel, or external companies (*e.g.*, independent laboratories) authorized to file on behalf of the Responsible Party must be provided. Information must be provided on company letterhead and include Company Name, Address, Phone Number, and Name and E-mail address for each individual listed. Additionally, at least one (maximum of three) individual(s) must be identified as a “Primary Contact.” Primary Contact(s) will be copied on all confirmation notices issued by the ACTA Secretariat, and serve as the company representative(s) for ACTA issues.

The ACTA Secretariat will issue confirmation notices via E-mail to the Authorized Submitter and/or Responsible Party typically within 7-10 days for Filings sent to the Secretariat. Contact the ACTA Secretariat if an E-mail is not received. An alternative method (*e.g.*, regular mail) is available on request. Incomplete or incorrect submissions will not be entered into the database until completed and/or corrected.

5.4 SDoC Posting on the ACTA Website

Parties informing the ACTA (pursuant to §68.324 (e)(3)) that a copy of the SDoC is not available to the general public, and accessible to the disabled community on a functional and reliable website that it maintains, are charged an additional \$425 (US) to make the SDoC publicly available on the ACTA website. This fee is in addition to the \$425 (US) fee for recording, updating, and maintaining information/content in the ACTA Database.

6 General Requirements

As specified in §68.326 and §68.610, TCBs and parties filing an SDoC shall maintain, and have readily available, records containing the following information (unless otherwise noted):

- 1) Copy of the SDoC; for SDoC Filings.
- 2) Copy of the TCB Certificate of Approval; for TCB Filings.
- 3) The identity of the testing facility, including the name, address, phone number and other contact information.
- 4) A detailed explanation of the testing procedure utilized to determine whether terminal equipment conforms to the appropriate technical criteria.
- 5) A copy of the test results for terminal equipment compliance with the appropriate technical criteria.

Responsible parties utilizing SDoCs shall maintain all records required under §68.326(a) for at least ten years after the manufacture of the equipment on file has been permanently discontinued. TCBs shall adhere to the guidelines specified in the National Institute of Standards and Technology (“NIST”) accreditation program under the applicable MRAs.

6.1 Indemnification and Liability Statements

Parties submitting information for inclusion in the Part 68 database of approved terminal equipment are required to provide the appropriate Indemnification and Liability Statement to the ACTA Secretariat. With the introduction of the ACTA Online Filing (“AOF”) system, however, two versions of the Indemnification and Liability Statement have been established.

The traditional statement specified in Appendix B is required to be submitted for each filing made directly to the ACTA Secretariat. The additional, and most recent, statement in Appendix C is required to be submitted to the ACTA Secretariat by parties that have filed with the ACTA Secretariat in the past and wish to use AOF. This statement, entitled “AOF Indemnification and Liability Statement,” is submitted only once for all AOF transactions. Parties filing an AOF statement are still required to provide the traditional statement when submitting information directly to the ACTA Secretariat. New parties registering on-line for a “Filer Account” will be required to agree to the statement before setting up their account.

In all cases, the Responsible Party shall indemnify and hold harmless the Administrative Council for Terminal Attachment (“ACTA”), its members, affiliates, Secretariat, and Sponsors, and each of their officers, directors, employees, participants, agents and representatives (the “ACTA Parties”), of and from any and all liabilities, losses, costs, damages, claims, suits or expenses (including reasonable attorneys’ fees and costs) of any kind whatsoever, arising from or relating to the Terminal Equipment (“TE”) or the Responsible Party’s Supplier’s Declaration of Conformity (“SDoC”) or Telecommunications Certification Body Grant of Certification submitted to the ACTA in connection therewith.

The responsible party shall acknowledge and agree that the ACTA, and the ACTA Parties shall not, and do not, assume, and expressly disclaim, any and all liability, responsibility and obligation in connection with any loss, damage or claim arising from or relating to, in any way, the ACTA's inactions or actions relating to publication, distribution or other use of any information relating to or concerning the TE, including without limitation in connection with any claims or liabilities sounding in contract, tort (including negligence or strict liability), or otherwise, and in no circumstances shall the ACTA or the ACTA Parties be liable for any loss of profits, loss of use, loss of production, loss of goodwill, or incidental, direct, indirect or consequential damages of any kind.

6.2 Consumer Information

The Administrative Council for Terminal Attachments ("ACTA") has revised its Customer Information⁴ to remove a perceived restriction on the connection of certain terminal equipment to the Public Switched Telephone Network ("PSTN") and certain private-lines services.

As the ACTA-adopted Consumer Information, Revision: July 2003, is intended to replace Consumer Information, Revision: March 2002, effective **January 1, 2005**, all Terminal Equipment ("TE") approved for connection to the PSTN and certain private-line services requiring such approval shall provide the Consumer Information contained therein.

As of September 1, 2002, Terminal Equipment ("TE") approved for connection to the Public Switched Telephone Network ("PSTN") and certain private-lines services, pursuant to 47 CF R §68.218(b)(1), must include ACTA-adopted Consumer Information.

6.3 FCC Issued Waivers

With the FCC's privatization of Part 68, the FCC handed-over to industry over 130 pages of the technical criteria previously contained in its Part 68 rules for industry's oversight, maintenance and continual development. The FCC also set in place rules that allow for any ANSI-accredited standards development organization ("SDO") to develop required technical criteria going forward for advanced technologies. Consequently, under these rules, technical criteria previously contained in Part 68 that are absorbed/assumed by (or additional criteria developed by) an ANSI-accredited SDO that are submitted and adopted by the ACTA would be deemed presumptively valid technical criteria by the FCC for Part 68 approval.

For this reason, requests for waivers (as historically defined) processed and granted by the FCC to technical criteria previously included in Part 68, and newly ACTA-adopted technical criteria, are no longer accepted by the FCC nor allowed by the ACTA. Parties developing and marketing products that fall outside established technical criteria or products for which technical criteria do not currently exist are now required to directly

⁴ The Customer Information in this document was originally prepared by the Telecommunications Industry Association's ("TIA") Committee TR-41.11 and subsequently adopted by the Administrative Council for Terminal Attachments ("ACTA") as a requirement for TE compliance with Part 68.

Guidelines & Procedures for Submittal of Information to the ACTA for Inclusion in the Database of Approved Telephone Terminal Equipment

pursue necessary modifications to existing criteria or the development of new criteria for Part 68 approval via an ANSI-accredited SDO. An SDO's acceptance of a technical change request to existing criteria or the development of new criteria will be based solely on the technical merit of the request, pursuant to ANSI procedures.

Aside from submitting a request for a waiver, parties may appeal ACTA-adopted technical criteria by filing opposition to: (1) the submitting SDO; (2) ANSI for procedural issues; or (3) the FCC directly for a de novo review pursuant to §68.614. Refer to the latest version of the ACTA Operating Principles and Procedures ("OP&P"), for more information on filing opposition to ACTA-adopted technical criteria.

In accordance with FCC Rules and Regulations (§68.218), parties acquiring approval of terminal equipment for connection to the public telephone network must warrant – whether through a TCB or an SDoC -- that each unit of equipment complies with all the applicable rules and regulations in 47 C.F.R. Part 68, and with the applicable ACTA-adopted technical criteria. Parties are required to also explicitly indicate the technical criteria under which the equipment was approved and to file this information with the ACTA for inclusion in its database of approved equipment.

In circumstances, therefore, where equipment has obtained approval as a result of a FCC granted waiver, parties filing this equipment for inclusion in the ACTA-maintained database are required to explicitly indicate on the SDoC or TCB certificate a reference to the technical criteria **and** a reference to the FCC-issued order wherein the FCC waived its requirements for approval (*i.e.*, "DA" number).

Guidelines & Procedures for Submittal of Information to the ACTA for Inclusion in the Database of Approved Telephone Terminal Equipment

Appendix A: Terminal Equipment Details (NORMATIVE)

Ref	Item Description
1a	Name of Organization Granting Approval of Equipment or Submitting Request for RPC
1b	TCB Identification Code ("ID"), if applicable
1c	Supplier's Declaration of Conformity ("SDoC"), if applicable
2	Terminal Approval Date
3	Product Identifier (selected by the responsible party: 1 to 9 digits)
4	Responsible Party Name and Address
5	US Agent for Service Name, Department, Address and Phone number
6	Equipment Description
7	Responsible Party Code ("RPC")
8	Manufacturer's Code(s)
9	Current ACTA or FCC product label number (only if Modification, Notice, Re-certification, and/or Re-declaration Filing)
10	Equipment Code
11a	List of Trade Names; including new & existing Trade Names
11b	List of Model Numbers including new & existing Model Numbers
12	Network address signaling code
13a	Consumer product characteristics -- AC REN
13b	Consumer product characteristics -- HAC
13c	Consumer product characteristics -- USOC jack(s) (N/A for equipment with no network connection)
13d	Consumer product characteristics -- Repeat dials to same number? (Yes or No)
14	Filing Status (Modification, Original, etc)
15	Facility Interface code ("FIC")
16	Manufacturer's Port ID
17	Service Order Code(s) ("SOC")
18	Answer Supervision Codes
19	Ancillary equipment (consoles, telephones, modems, external power supplies, etc.)

Definition of Terminal Equipment Detail Items:

Item 1a: Name of Organization Granting Approval of Equipment or Submitting Request for RPC

List the complete name and address of the organization (including the contact information of the submitter; *i.e.*, E-mail and phone number) attesting to the terminal equipment's conformity to Part 68 rules and ACTA-adopted technical criteria, or the name of the organization applying for an RPC. Authorized Submitters (*e.g.*, Agents) forwarding information to the ACTA on behalf of a Responsible Party utilizing the SDoC method should use the table entitled "Submitter's Information."

Item 1b: Telecommunications Certification Body Identification Number

List the TCB identifier for terminal equipment information submitted by a registered TCB.

Item 1c: Supplier's Declaration of Conformity

Provide a copy of the SDoC for terminal equipment submitted under an SDoC.

Item 2: Terminal Equipment Approval Date

Provide the date the terminal equipment was approved (date of TCB Certificate or SDoC Statement).

Item 3: Product Identifier

Provide the responsible party's unique terminal identifier. Refer to *TIA Telecommunications Systems Bulletin ("TSB") -168-A, Telecommunications –Telephone Terminal Equipment –Labeling Requirements*. Example: **US: AAAEQ##TXXX**, where xxx is the product identifier. The Responsible Party shall define this identifier.

Note; the FCC historically assigned a 5-digit product identifier number. Example: **AAABBB-NNNNN-XX-Y**, where NNNNN is the assigned number. Parties submitting data for products that will retain its existing FCC Registration number (Modification, or Notice of Change) should enter the FCC-assigned 5 digit number.

Item 4: Responsible Party

List the complete name and address of the responsible party; including the contact information of the submitter; *i.e.*, E-mail and phone number. The Responsible Party is the individual or company that accepts responsibility for the product and its compliance to Part 68 rules and ACTA-adopted technical criteria. Pursuant to the "Order on Reconsideration in CC Docket No. 99-216 and Order Terminating Proceeding in CC Docket No. 98-163," FCC 02-103, Released April 10, 2002, the Responsible Party is not required to be located in the United States but, must designate an agent for service of process that is physically located in the United States. See Item #5. For parties utilizing the SDoC method, this may be the same information contained in Item 1a.

Item 5: Agent for Service

Original Filings will not be processed without an Agent for Service. The Responsible Party, whether they file using the Supplier’s Declaration of Conformity (SDoC) or TCB Certification method, must designate an agent for service of process that is physically located within the United States. The Agent for Service is an entity upon which service may be made of all inquiries, orders, decisions, and other pronouncements of the FCC in any matter before the FCC. Responsible Parties must identify an agent (or department designation), business address, phone number and, if available, TTY (teletypewriter) number, facsimile number, and Internet E-mail address.

Item 6: Equipment Description

For an Original Filing provide a brief description (in 10 words or less) of the terminal equipment. Example: ‘Two-line telephone with built-in answering machine.’ For Modification Filings, provide a brief description of the technical change.

Item 7: Responsible Party Code (“RPC”)

List Responsible Party’s assigned ACTA RPC or FCC CCB assigned Applicant Code. Refer to Section 3, General Filing Guidelines.

Item 8: Manufacturer Code

List manufacturer's previously assigned FCC ID code(s), if known; otherwise leave blank.

Item 9: Current ACTA or FCC Product Label Number

Provide current product label number. This could be the ACTA “US” Number or FCC certification or registration number(s). This is required for Modification, Notice of Change, and Re-certification Filings.

Item 10: Equipment Code

Refer to *TSB-168-A, Telecommunications –Telephone Terminal Equipment –Labeling Requirements* for a complete list of codes. Only one code may be specified. Select the code that best matches your product. If your equipment is currently approved, include the equipment code already assigned to your equipment.

Item 11a: List of Brand or Trade Names including new & existing Names

List of Trade or Brand Names, including new and existing Trade Names, under which this product will be marketed and sold. Note: The type of application being made impacts what information is to be included in this field. *See also* Item 14.

Item 11b: List of Model Numbers including new & existing Brand or Trade Names

List of model numbers for each Trade or Brand Name under which this product will be marketed and sold. Note: The type of application being made impacts what information is to be included in this field. *See also* Item 14.

Item 12: Network Address Signaling Code

Show the network address signaling code. This is required for all applications. Indicate the type of network address signaling by one of the following code letters:

- T If the device performs dual-tone multi-frequency (“DTMF”) signaling;
- R If the device performs rotary (pulse) signaling;
- E If the device performs either DTMF or pulse signaling (selectable);
- N If the device does no signaling.

Item 13a: AC Ringer Equivalence Number (“REN”)

The format used to enter the AC REN is, ##T. The "##" symbols represents the REN. The "T" represents the ringer type associated with the REN. In the case of a “Z” ringer, “ZZ” shall be used for the REN. Note: the code for approved equipment without a network interface and equipment not connecting to circuits with analog ringing supplied, is “NAN.” Examples of a valid REN format are: "10A," "01B," "NAN," and "ZZZ." Refer to *TSB-168-A, Telecommunications -Telephone Terminal Equipment -Labeling Requirements*.

Item 13b: Hearing Aid Compatible (“HAC”)

Telephones (corded and cordless) imported into (or manufactured in) the U.S., unless otherwise exempt, must be HAC (magnetic flux strength, §68.316). Marking of devices with the letters HAC prominently displayed is required for all HAC telephones manufactured or imported after April 1997. Enter Yes, No, or Not Applicable (N/A).

Item 13c: Universal Service Order Codes (“USOC”) Jacks

List type(s) of jack(s) required at the network interface. Use N/A for adjuncts that do not make direct connection to the network. Use "hardwired" for meter readers and alarm dialers, if applicable (some alarm dialers preferentially use the type RJ31X jack because of its call preemption feature). Refer to *ATIS Technical Report No. 5*.

Item 13d: Repetitive Dialing to a Single Number

Many telephones, dialers, and alarm systems have the capability of repeat dialing to a single number. Indicate if the device or system has this feature. In CC Docket No. 81-216, Fourth Notice of Proposed Rulemaking, FCC 86-352, the Commission permitted computer-controlled automatic redialing but reserved the right to revisit this decision to ensure network protection, if necessary. Enter Yes or No.

Item 14: Filing Status

Describe the primary reason for the Filing. Each Filing must demonstrate that the covered equipment will not harm the network.

Original Filing

Original Filings are required for covered equipment to be sold that previously has not been approved. Each Filing must be complete and without reference to a previously submitted application.

Modification Filing

Modification Filings are required to maintain database accuracy when a change that alters the compliance characteristics has been made to the equipment, such as network interface circuitry, as filed under an original application. A Modification Filing is required when these changes affect the contents of the ACTA-maintained database of approved Part 68 products, a Responsible Party's SDoC, or a TCB's Certificate. A Modification Filing will be processed only when an Original Filing for the terminal equipment has previously been processed.

Note: Should any change alter the product label, it would require a new Original Filing.

Blanket Modifications

The Blanket Modification allows a single product or product family that has more than one approval number to be changed for one Filing. A product family is a number of products, each having two or more approval numbers, where all of the approval numbers appear on each product. Similarly, all listings for a product approved for different manufacturing sites before the FCC's use of the "MUL" designator to signify multiple country codes can also be changed using a Blanket Modification.

For example, Blanket Modifications may be used to change the listings for a PBX or family of PBXs with several approval numbers as long as each product in the family has all the same approval numbers.

A Blanket Modification may not be used if the products being considered have a range of approval numbers that are not common to all products. For example, a corded phone, a cordless phone, and a corded speakerphone each with its own unique approval number cannot be changed using a Blanket Modification.

Because of the possibility of confusion and invalid or incomplete entries in the database, all Blanket Modifications must be submitted on CD ROM to the ACTA Secretariat for processing.

Notice of Change (“Notice”) Filing

Notice Filings are required to maintain database accuracy when no electrical change has been made to the equipment that alters the compliance characteristics, such as network interface circuitry, as filed under an original application. A notice Filing is required, for example, when a trade name, model number, or some feature that does not affect compliance characteristics is added to a previously approved device or system. Typically, such additions describe cosmetic variations, or are for marketing the product under a different trade name or model number.

Re-certification/Re-approval

Re-certification/Re-approval applications are required for limited cases requiring the processing of a new filing. They can include:

- (a) Changes in the network address signaling code (*e.g.*, changing from a T to an E), for products using the historical FCC Registration Number format;
- (b) Establishing a new classification for equipment (*e.g.*, a change to a MF classification based on a previously approved KF system);
- (c) Adding a new manufacturer; when manufacturing/distribution rights are transferred to another party;
- (d) When a vendor wants its own product identification number for marketing reasons (with permission of the original responsible party);
- (e) When changing from the FCC Reg. number format to the ACTA “US” number format.

Re-certification/Re-approval Filings will result in a new product identification number. Products using the historical FCC Reg. number will be required to change over to the ACTA “US” number.

In the event a 3rd party vendor wants its own product identification number on a product also distributed by the original Responsible Party, as noted under case (d) above, the 3rd party’s product will be listed in the database as an “Original” Filing. Accordingly, the 3rd party vendor shall assume full responsibility, as specified in 47 C.F.R. Part 68, for the products distributed under its Responsible Party Code (RPC). Refer to Section 3.2 for more information.

In the event a Responsible Party elects to distribute both the original product and the new product stemming from a Re-certification/Re-approval, as noted in cases (a) and (b) above, the new product(s) are considered “self-standing” product(s) and thus must be filed in the database as an “Original” Filing. Users of AOF must consider this circumstance and submit their filings accordingly.

Item 15: Facility Interface Codes (“FIC”)

The FIC identifies the type of interface that the terminal equipment requires for compatible interconnection with wireline carrier facilities. A partial list of the more commonly used FIC codes is provided in the table below.

Many FIC codes use the Network Channel Interface (NCI) Code structure described in ANSI T1.223-1997, American National Standard for Telecommunications - Information Interchange - Structure and representation of Network Channel (NC) and Network Channel Interface (NCI) Codes for the North American Telecommunications System [1]. Additional NCI codes and their definitions may be found in ATIS Technical Report #5. A full list may be found in the NC/NCITM Decoder [2], a computer-based application developed by Telcordia Technologies (as Maintenance Agent per T1.223) and updated quarterly.

Guidelines & Procedures for Submittal of Information to the ACTA for Inclusion in the Database of Approved Telephone Terminal Equipment

[1] Alliance for Telecommunications Industry Solutions
 1200 G Street, N.W., Suite 500
 Washington, DC 20005
 (202) 434-8845

[2] Telcordia Technologies
 8 Corporate Place
 Piscataway, NJ 08854
 1-800-521-2673

Analog Services	
FIC	Description
OL13A.	2-wire, Class A, Private Branch Exchange (“PBX”) off-premises station port
OL13B	2-wire, Class B, PBX off-premises station port.
OL13C	2-wire, Class C, PBX off-premises station port.
LADC	Local area data channels *
METALLIC	2- or 4-wire metallic private line. *
TL11E	E&M Tie Trunk, Lossless, 2W, Type I, originates with ground on E
TL11M	E&M Tie Trunk, Lossless, 2W, Type I, originates with battery on M
TL12E	E&M Tie Trunk, Lossless, 2W, Type II, originates with ground on E
TL12M	E&M Tie Trunk, Lossless, 2W, Type II, originates with battery on M
TL31E	E&M Tie Trunk, Lossless, 4W, Type I, originates with ground on E
TL31M	E&M Tie Trunk, Lossless, 4W, Type I, originates with battery on M
TL32E	E&M Tie Trunk, Lossless, 4W, Type II, originates with ground on E
TL32M	E&M Tie Trunk, Lossless, 4W, Type II, originates with battery on M
02AC2	2-wire voice transmission with customer-provided ringing 600 ohms*
02GS2	2-wire ground-start signaling closed end provided by end user 600 ohms
02LA2	2-wire, certified, Class A, PBX off-premises station port 600 ohms
02LB2	2-wire, certified, Class B, PBX off-premises station port 600 ohms
02LC2	2-wire, certified, Class C, PBX off-premises station port 600 ohms
02LR2	2-wire Private Line Automatic Ringdown, ringing from Local Exchange Carrier (“LEC”), 600 ohms*
02LS2	2-wire loop-start signaling closed end provided by end user 600 ohms
02NO2	4-wire voice transmission with no LEC-provided signaling 600 ohms*
02RV2.0	2-wire loop reverse battery signaling, loop closure from customer, reverse battery from LEC, 600 ohms. Used for PBX-E911 trunks. *
02RV2.T	2-wire loop reverse battery signaling, loop closure from customer, reverse battery from LEC, 600 ohms. Used for Direct Inward Dialing (“DID”) ports.
04AC2	4-wire voice transmission with customer-provided ringing 600 ohms*
04GS2	4-wire ground-start signaling closed end provided by end user 600 ohms*
04LR2	4-wire Private Line Automatic Ringdown, ringing from LEC, 600 ohms*
04LS2	4-wire loop-start signaling closed end provided by end user 600 ohms*
04NO2	4-wire voice transmission with no LEC-provided signaling 600 ohms. (Applicable to “hoot ‘n holler” circuits.) *
04RV2.T	2-wire loop reverse battery signaling, loop closure from customer, reverse battery from LEC, 600 ohms. Used for DID ports. *
06EA2.M	6-wire Type I E&M signaling – Battery on M lead to originate, 600 ohms. Same as TL31M except with transmit TLP values of -2 to +3 dBm.
08EB2.M	8-wire Type II E&M signaling – Battery on M lead to originate, 600 ohms. Same as TL31M except has expanded receive TLP values of 0 to –8 dBm.

Guidelines & Procedures for Submittal of Information to the ACTA for Inclusion in the Database of Approved Telephone Terminal Equipment

Digital Services	
FIC	Description
02DU5.56B	2-wire Switched 56 kbps Type III Public Switched Data Service ("PSDS"), 135 ohms.
02DU7.56B	2-wire Switched 56 kbps Type II PSDS, 124 ohms.
02IS5	2-wire Basic Rate Integrated Services Digital Network ("ISDN"), 135 ohms.
04DU5.19	4-wire 19.2 kbps digital interface, 135 ohms.
04DU5.19S	4-wire 19.2 kbps digital interface with secondary channel, 135 ohms.
04DU5.24	4-wire 2.4 kbps digital interface, 135 ohms.
04DU5.24S	4-wire 2.4 kbps digital interface with secondary channel, 135 ohms.
04DU5.38	4-wire 38.4 kbps digital interface, 135 ohms.
04DU5.38S	4-wire 38.4 kbps digital interface with secondary channel, 135 ohms.
04DU5.48	4-wire 4.8 kbps digital interface, 135 ohms.
04DU5.48S	4-wire 4.8 kbps digital interface with secondary channel, 135 ohms.
04DU5.56	4-wire 56 kbps digital interface, 135 ohms.
04DU5.56B	4-wire Switched 56 kbps Type I PSDS, 135 ohms.
04DU5.56S	4-wire 56 kbps digital interface with secondary channel, 135 ohms.
04DU5.64	4-wire 64 kbps digital interface, 135 ohms.
04DU5.96	4-wire 9.6 kbps digital interface, 135 ohms.
04DU5.96S	4-wire 9.6 kbps digital interface with secondary channel, 135 ohms.
04DU9.BN	4-wire 1.544 Mbps (DS1) with Super Frame ("SF"), Alternate Mark Inversion ("AMI"), no line power, 100 ohms.
04DU9.DN	4-wire 1.544 Mbps (DS1) with SF, Bipolar with eight-zero substitution ("B8ZS"), no line power, 100 ohms.
04DU9.1KN	4-wire 1.544 Mbps (DS1) with Extended Super Frame ("ESF"), AMI, no line power, 100 ohms.
04DU9.1SN	4-wire 1.544 Mbps (DS1) with ESF, Bipolar with Eight-Zero Substitution ("B8ZS"), no line power, 100 ohms. *

Analog Services: * These services are subject to local availability

Digital Services: * May be used for Primary Rate ISDN.

Item 16: Manufacturer Port ID

Manufacturer's part number or model number for circuit pack or card for that specific network port.

Item 17 & 18: Service Order Codes ("SOC") and Answer Supervision Codes

A partial list of the most commonly used codes is provided below.

Service Order Codes	
Analog Services	
SOC	Description
9.0F	Full protection to the network from systems using live voice. Only approved terminal equipment can be connected to station ports.
9.0N	Unprotected systems. Requires use of certified protective couplers or filing of affidavits with the telco. <i>See</i> §68.215(d) and (e)
9.0Y	Provides full Part 68 protection. Provides signal limiting for ALL signal sources (not just from Music On Hold ("MOH")).
7.0Y	Provides total protection to the network for connection of private communication systems.
7.0Z	Host system port provides partial protection to the network for connection of private communication systems. Requires filing of signal power affidavit with telco.

Guidelines & Procedures for Submittal of Information to the ACTA for Inclusion in the Database of Approved Telephone Terminal Equipment

Digital Services	
SOC	Description
6.0Y	Provides total protection, including billing protection and encoded analog content.
6.0F	Combinations of equipment provide full protection to digital service. Billing protection and encoded analog protection are provided either by including auxiliary equipment within the certification envelope or by use of a separately certified device.
6.0N	Does not provide billing and encoded analog protection. Uses either an integrated or external Channel Service Unit ("CSU"). Affidavit to telco is required.
6.0P	Provides billing and encoded analog protection (similar to 6.0F) but requires separate CSU.

Answer Supervision Codes for Systems and Terminal Equipment	
Code	Description
AS.2	System ports that provide answer supervision (for system types such as CD, KF, MF, PF, VM, etc.)
AS.3	Terminal equipment or combinations of terminal equipment that provides answered supervision.

Note: Include as a Service Order Code

Item 19: Ancillary Equipment

Enter each model and list subsystem elements by name and manufacturer's port number that fall within the product's registration/certification "envelope." If telephones and consoles are HAC, indicate by using HAC. Note; information is not required for single and two line devices. For cordless phones used as stations, indicate the frequency band used and that digital security coding is employed.

	Certification Status*	Trade Name	Model Number	List of Ancillary Equipment by Type**	Manufacturer's Identifier
1					
2					
3					

*The certification status column indicates the type of filing for all entries using these codes:

Status Code Definition of Code

NEW -- New with this submission

MOD -- Modified from previous submissions

PREV -- Previously certified, no change

MD -- Manufacturing Discontinued, may exist in product in the field

RECERT -- Re-Certification

**This includes items such as, but not limited to, consoles, telephones, external power supplies, and modems.

Appendix B: Indemnification and Liability Statement (NORMATIVE)

Date

ACTA Secretariat
c/o ATIS
1200 G Street, NW
Suite 500
Washington, DC 20005

RE: Statement of Indemnification and Liability, and additional information about the *<insert product name, model number, and product-labeling number (ACTA or FCC)>* (the “Product”).

ACTA Secretariat:

<Responsible party> hereby indemnifies and holds harmless the Administrative Council for Terminal Attachment (“ACTA”), its members, affiliates, Secretariat, and Sponsors, and each of their officers, directors, employees, participants, agents and representatives (the “ACTA Parties”), of and from any and all liabilities, losses, costs, damages, claims, suits or expenses (including reasonable attorneys’ fees and costs) of any kind whatsoever, arising from or relating to the Product, or *<Responsible party’s>* Supplier’s Declaration of Conformity (“SDoC”) or Telecommunications Certification Body (“TCB”) Grant of Certification submitted to the ACTA in connection therewith.

<Responsible party> hereby acknowledges and agrees that the ACTA, and the ACTA Parties shall not, and do not, assume, and expressly disclaim, any and all liability, responsibility and obligation in connection with any loss, damage or claim arising from or relating to, in any way, the ACTA’s inactions or actions relating to publication, distribution or other use of any information relating to or concerning the Product, including without limitation in connection with any claims or liabilities sounding in contract, tort (including negligence or strict liability), or otherwise, and in no circumstances shall the ACTA or the ACTA Parties be liable for any loss of profits, loss of use, loss of production, loss of goodwill, or incidental, direct, indirect or consequential damages of any kind.

Pursuant to §68.218 and §68.348 in the FCC Rules and Regulations, no changes will be made to the above referenced Product or its protective circuitry that would result in any change in the information contained in the corresponding SDoc or TCB Grant of Certification *<insert SDoc or TCB Grant of Certification Reference Number (if applicable) >* without filing of a new SDoc or TCB Grant of Certification.

[Submitter note: use the following language, if applicable.]

As specified in §68.324 (e)(3) a copy of the SDoc is freely available to the general public, and accessible to the disabled community, on the company website at *<insert URL>*.

Guidelines & Procedures for Submittal of Information to the ACTA for Inclusion in the Database of Approved Telephone Terminal Equipment

[Submitter note: use the following alternative language, if applicable.]

In accordance with §68.324 (e)(3), *<Responsible party>* hereby informs the ACTA that a copy of the SDoC is not available to the general public, and accessible to the disabled community on a functional and reliable website that it maintains.

<Name of company officer>

<Function of officer>

<Signature>

Submitter Notes:

- (1) This statement is considered a legally binding contract and must be signed by individuals authorized to enter into a contractual agreement.
- (2) The product-labeling number must be included where indicated. This number is the ACTA product-labeling number (per TSB-168-A), or the previously assigned full FCC Registration number.
- (3) The submitter notes in the statement should be removed from the statement before submitting it to the ACTA Secretariat.
- (4) Parties filing TE information with the ACTA Secretariat for inclusion into the Part 68 database must provide the above statement with each and every submission.

Appendix C: AOF Indemnification and Liability Statement (NORMATIVE)

Date

ACTA Secretariat
c/o ATIS
1200 G Street, NW
Suite 500
Washington, DC 20005

RE: Statement of Indemnification and Liability for use of the ACTA Online Filing (“AOF”) system

ACTA Secretariat:

To access the ACTA Online Filing (“AOF”) database of Part 68 approved terminal equipment (“TE”), I acknowledge that it is necessary for each entity, organization and individual, whether accessing the database on its own behalf or on behalf of another, including each Telecommunications Certification Body (a "TCB") and each Responsible Party (an “RP”), to obtain a password. By submitting this statement, I agree to the following terms and conditions and request a password.

As a Responsible Party I agree to indemnify and hold harmless the Administrative Council for Terminal Attachment ("ACTA"), its members, affiliates, Secretariat, and Sponsors, and each of their officers, directors, employees, participants, agents and representatives (the "ACTA Parties"), of and from any and all liabilities, losses, costs, damages, claims, suits or expenses (including reasonable attorneys' fees and costs) of any kind whatsoever, arising from or relating to submissions, filings, or information submitted to the ACTA, or the Responsible Party's Supplier's Declaration of Conformity ("SDoC") or Telecommunications Certification Body ("TCB") Grant of Certification submitted to the ACTA in connection therewith.

I further acknowledge and agree that the ACTA, and the ACTA Parties shall not, and do not, assume, and expressly disclaim, any and all liability, responsibility and obligation in connection with any loss, damage or claim arising from or relating to, in any way, the the ACTA's inactions or actions relating to publication, distribution or other use of any information relating to or concerning submissions, filings, or information submitted to the ACTA, including without limitation in connection with any claims or liabilities sounding in contract, tort (including negligence or strict liability), or otherwise, and in no circumstances shall the ACTA or the ACTA Parties be liable for any loss of profits, loss of use, loss of production, loss of goodwill, or incidental, direct, indirect or consequential damages of any kind.

I further agree that pursuant to §68.218 and §68.348 in the FCC Rules and Regulations, no changes will be made to terminal equipment submitted to the ACTA for inclusion in the database of approved Part 68 equipment or the protective circuitry that would result in any change in the

Guidelines & Procedures for Submittal of Information to the ACTA for Inclusion in the Database of Approved Telephone Terminal Equipment

information contained in the corresponding SDoC or TCB Grant of Certification without filing of a new SDoC or TCB Grant of Certification.

Where applicable, I also agree to make freely available to the general public and accessible to the disabled community a copy of any SDoC I submitted to the ACTA database of Part 68 approved TE or, in the alternative, to cause a copy of any SDoC I submitted to be freely available to the public via the ACTA website with the understanding that such service may be subject to an administrative fee.

I UNDERSTAND THAT AGREEMENT TO THE FOREGOING SHALL BE BINDING ON MYSELF, AS WELL AS ON EACH ENTITY AND ORGANIZATION ON WHOSE BEHALF I AM ACTING IN CONNECTION WITH THE ACTA DATABASE. IN ADDITION I AGREE TO BE BOUND TO EACH OF THE FOREGOING TERMS AND CONDITIONS TO THE EXTENT THEY ARE AGREED TO BY ANY ENTITY, ORGANIZATION OR INDIVIDUAL THAT, IN CONNECTION WITH THE ACTA DATABASE, REPRESENTS ITSELF OR HIMSELF TO BE ACTING ON MY BEHALF OR ON BEHALF OF ANY ENTITY OR ORGANIZATION REPRESENTED BY ME IN CONNECTION WITH THE ACTA DATABASE.

<Name of company officer>

<Function of officer>

<Signature>

Submitter Notes:

(1) Parties that have submitted information to the ACTA in the past and wish access to AOF must submit the above statement to the ACTA Secretariat before a AOF Passcode is assigned.

Appendix D: Example Language for an SDoC (NORMATIVE)

Supplier's Declaration of Conformity

Reference Number: _____ (Optional)

Place of Issue: _____

Date of Issue: _____

<Responsible party> located at **<company address>** in the United States of America hereby certifies that the **<product name and model number>** bearing labeling identification number **<product-labeling number (based on TSB-168-A or FCC Part 68) >** complies with the Federal Communications Commission's ("FCC") Rules and Regulations 47 CFR Part 68, and the Administrative Council on Terminal Attachments ("ACTA")-adopted technical criteria **<specification number(s), title, revision, and date of issue of each ACTA-adopted technical criteria including addendums in effect at the time of submission of the equipment to the ACTA database>**. [Submitter note: Provided is an example of the technical criteria format: TIA-968-A, Telecommunications – Telephone Terminal Equipment -Technical Requirements for Connection of Terminal Equipment To the Telephone Network, January 2003, TIA-968-A-1; TIA-968-A-2; TIA-968-A-3.]

[Submitter note: insert the following (if applicable) for a product (with a handset) compliant with §68.316.]

<Responsible party> hereby asserts that the **<product name and model number>** complies with §68.316 of the FCC Rules and Regulations defining Hearing Aid Compatible ("HAC") and, as such, is deemed compatible with hearing aids.

[Submitter note: insert the following (if applicable) for a product (with a handset) that is not compliant with §68.316.]

<Responsible party> hereby issues notice that the **<product name and model number>** is not compliant with §68.316 of the FCC Rules and Regulations defining Hearing Aid Compatible ("HAC"). Accordingly, the FCC prohibits the use of this product in certain locations, such as, **<insert list of locations per §68.112>**.

[Submitter note: insert the following if equipment is designed to operate in conjunction with other equipment, the characteristics of which can affect compliance, as specified in §68.324(b).]

<Responsible party> hereby asserts that the **<product name and model number>** is designed to operate in conjunction with other equipment, the characteristics of which can affect compliance of the **<product name and model number>** with Part 68 Rules and Regulations and/or with technical criteria adopted by the ACTA. The other equipment is **<list all product name(s) and**

Guidelines & Procedures for Submittal of Information to the ACTA for Inclusion in the Database of Approved Telephone Terminal Equipment

model number(s)> and the <*Supplier's Declaration of Conformity or Telecommunications Certification Bodies certificate(s)*> relevant to each product listed are enclosed.

<*Name of company officer*>

<*Function of officer*>

<*Signature*>

Submitter Notes:

- (1) This statement is considered a legally binding contract and must be signed by individuals authorized to enter into a contractual agreement.
- (2) The product-labeling number must be included where indicated. This number is the ACTA product-labeling number (per TSB-168-A), or the previously assigned full FCC Registration number.
- (3) The submitter notes in the statement should be removed from the statement before submitting it to the ACTA Secretariat.

Appendix E: Consumer Information (INORMATIVE)

**Administrative Council for Terminal Attachments (ACTA)
Customer Information**

Revision: July 2003

Background:

The Administrative Council for Terminal Attachments (“ACTA”) has revised its Customer Information⁵ to remove a perceived restriction on the connection of certain terminal equipment to the Public Switched Telephone Network (“PSTN”) and certain private-lines services. The major changes were to the Alarm Dialing Equipment section. The Customer Information contained in this document (Consumer Information, Revision: July 2003), has been adopted by the ACTA and may be used immediately for terminal equipment approvals at the Responsible Party’s discretion.

As the ACTA-adopted Consumer Information, Revision: July 2003, is intended to replace Consumer Information, Revision: March 2002, effective **January 1, 2005**, all Terminal Equipment (“TE”) approved for connection to the PSTN and certain private-line services requiring such approval shall provide the Consumer Information contained herein.

As of September 1, 2002, Terminal Equipment (“TE”) approved for connection to the Public Switched Telephone Network (“PSTN”) and certain private-lines services, pursuant to 47 CF R §68.218(b)(1), must include ACTA-adopted Consumer Information.

Customer Information:

The following customer information must be provided to customers with each unit of approved terminal equipment. Please note that there are differences in the information required for consumer products, coin/credit card phones, systems and digital equipment.

Wherever possible example wordings that meet the requirement have been provided. Text in *[Italics]* is product or manufacturer specific information.

If the equipment is being approved by the Telecommunications Certification Body (“TCB”) process, a copy of the required customer information must be provided to the TCB. These materials must be identical to what is provided to the customer.

While the information specified here must be provided to the customer, Responsible Parties have the option of either providing that information in printed form, or in whatever alternative form the user manual is provided. Alternative methods include disk, CD-ROM, or via the Internet.

⁵ The Customer Information in this document was originally prepared by the Telecommunications Industry Association’s (“TIA”) Committee TR-41.11 and subsequently adopted by the Administrative Council for Terminal Attachments (“ACTA”) as a requirement for TE compliance with Part 68.

Guidelines & Procedures for Submittal of Information to the ACTA for Inclusion in the Database of Approved Telephone Terminal Equipment

The goal is to make sure the information is readily available to users while minimizing the burden on manufacturers.

It is sometimes the practice to ship product in large quantities (bulk) from the manufacturer to a distributor or reseller without customer instructions. This is acceptable as long as the required information accompanies each unit shipped to the end customer.

General Requirements For All Equipment:

- a) For equipment approved after July 23, 2001, include the following paragraph:

This equipment complies with Part 68 of the FCC rules and the requirements adopted by the ACTA. On the *[insert location of the label]* of this equipment is a label that contains, among other information, a product identifier in the format US:AAAEQ##TXXXX. If requested, this number must be provided to the telephone company.

For equipment approved prior to July 23, 2001, include this paragraph:

This equipment complies with Part 68 of the FCC rules. On the *[insert location of the label]* of this equipment is a label that contains, among other information, the FCC registration number and ringer equivalence number (REN) for this equipment. If requested, this information must be provided to the telephone company.

- b) List all applicable certification jack Universal Service Order Codes (“USOC”) for the equipment. For some types of analog and digital systems, list associated Facility Interface Codes (“FIC”) and Service Order Codes (“SOC”). These are required when the customer orders service from the local telephone company. Refer to Alliance for Telecommunications Industry Solutions (“ATIS”) Technical Report No. 5 for a more extensive listing of jack configurations and their designations (*e.g.*, RJ11C), or refer to the Telcordia NC/NCITM Decoder for a full listing.
- c) State that for single and two-line equipment that connects to the telephone network via a plug and jack, the plug and jack used with this equipment must comply with FCC Part 68 rules. Use words similar to the following:

A plug and jack used to connect this equipment to the premises wiring and telephone network must comply with the applicable FCC Part 68 rules and requirements adopted by the ACTA. A compliant telephone cord and modular plug is provided with this product. It is designed to be connected to a compatible modular jack that is also compliant. See installation instructions for details.

- d) Explain the Ringer Equivalence Number (or REN) and its use. Note: RENs are associated with loop-start and ground-start ports. Do not use for E&M or digital ports. Use words similar to the following:

The REN is used to determine the number of devices that may be connected to a telephone line. Excessive RENs on a telephone line may result in the devices not ringing

Guidelines & Procedures for Submittal of Information to the ACTA for Inclusion in the Database of Approved Telephone Terminal Equipment

in response to an incoming call. In most but not all areas, the sum of RENs should not exceed five (5.0). To be certain of the number of devices that may be connected to a line, as determined by the total RENs, contact the local telephone company. For products approved after July 23, 2001, the REN for this product is part of the product identifier that has the format US:AAAEQ##TXXXX. The digits represented by ## are the REN without a decimal point (*e.g.*, 03 is a REN of 0.3). For earlier products, the REN is separately shown on the label.

- e) Provide information on what will happen if this equipment causes harm to the telephone network. Use words similar to the following:

If this equipment [*insert identity of equipment*] causes harm to the telephone network, the telephone company will notify you in advance that temporary discontinuance of service may be required. But if advance notice isn't practical, the telephone company will notify the customer as soon as possible. Also, you will be advised of your right to file a complaint with the FCC if you believe it is necessary.

- f) Provide information on what will happen if the telephone company makes changes that could affect this equipment. Use words similar to the following:

The telephone company may make changes in its facilities, equipment, operations or procedures that could affect the operation of the equipment. If this happens, the telephone company will provide advance notice in order for you to make necessary modifications to maintain uninterrupted service.

- g) State what to do if there are problems with this equipment. Use words similar to the following:

If trouble is experienced with this equipment [*insert identity of equipment*], for repair or warranty information, please contact [*company name or service center in the U.S.A., phone number, and website address if available*]. If the equipment is causing harm to the telephone network, the telephone company may request that you disconnect the equipment until the problem is resolved.

- h) Explain which repairs, if any, the customer (user) can perform. If there is a section in the general customer instructions that provides detailed information on repairs, a reference to that section is acceptable. If this equipment is of a type that is not intended to be repaired, state that fact in place of any repair instructions.

- i) State that this equipment must not be used on party lines. Use words similar to the following:

Connection to party line service is subject to state tariffs. Contact the state public utility commission, public service commission or corporation commission for information.

- j) Include a caution to users who may have alarm dialing equipment. Use words similar to the following:

Guidelines & Procedures for Submittal of Information to the ACTA for Inclusion in the Database of Approved Telephone Terminal Equipment

If your home has specially wired alarm equipment connected to the telephone line, ensure the installation of this [*equipment ID*] does not disable your alarm equipment. If you have questions about what will disable alarm equipment, consult your telephone company or a qualified installer.

- k) If this equipment uses a telephone handset, state that it is hearing aid compatible. Use words similar to the following:

This equipment is hearing aid compatible.

Customer-Owned Coin/Credit Card Phones:

The instructions that are provided with each customer-owned coin or credit card phone must include the following notice:

To comply with state tariffs, the telephone company must be given notification prior to connection. In some states, the state public utility commission, public service commission or corporation commission must give prior approval of connection.

Data Equipment:

For permissive, programmable and (or) fixed loss loop operation data equipment, in addition to the general requirements for all equipment, information must be provided explaining which jack is associated with each operation.

Permissive, use RJ11C

Programmable, use RJ41S and RJ45S

Fixed Loss Loop, use RJ41S

Refer to ATIS Technical Report No. 5 for details on these connectors.

For Private (Leased) Line (Analog Data Format) equipment, the type JM8 jack is required. Refer to ATIS Technical Report No. 5 for details on this connector.

For Private (Leased) Line (Digital Format) equipment, in addition to the general requirements for all equipment, certain digital connections require that an encoded analog content and billing protection affidavit be provided the telephone company. Customer instructions must contain information on the preparation and submission of the affidavit.

Private (Leased) Lines For Analog Services:

The Facility Interface Code (FIC) associated with each private line application represents the type of service that will be provided by the telephone company. The user instructions must contain a detailed list of private line ports and the associated FICs for which the equipment has been approved. In addition, the Service Order Code (SOC) must also be included for analog systems. The SOC indicates the degree of network protection provided by the equipment. For some details on applicable FICs and SOCs refer to section 2b above.

Note: Some services may not be available in all locations.

Systems:

The consumer instructions for systems must contain information on all connectors to the network (switched and private line). This information includes the jack USOCs, FICs, SOC's, the REN if applicable, the premises wiring information, and any affidavits or written authority authorizations. Furthermore, the US:AAA EQ##TXXX number of the system must be provided so the telephone service provider can ascertain intended modes of operation and verification of certification ports.

Adjuncts - KX and PX Devices:

The consumer information must contain notification that when the adjunct is used with a leased system, permission of the owner of the equipment must be obtained for connection of the adjunct because modification of the host system is often required.

Customer instructions for KX type telephones with medium impedance analog message waiting lights and/or line status indicators must contain statements that they can only be connected to host equipment and never directly to the network. The reason is that they do not meet the 5 mega ohm requirement and most likely will create excessive leakage current when polled by the telephone company's daily automatic loop insulation test equipment. Such events trigger a maintenance action by the telephone company to determine the location of such leakage currents.

OEM Devices:

When approved equipment such as couplers or modems are furnished to the OEM market (final equipment assemblers), the consumer instructions must contain the following information:

The mounting of the approved unit in the final assembly must be made so that the approved unit is isolated from exposure to any hazardous voltages within the assembly. Adequate separation and restraint of cables and cords must be provided.

The circuitry from the approved unit to the telephone line must be provided in wiring that carries no other circuitry (such as PC or PR leads) unless specifically allowed by the rules. PC board traces carrying tip and ring leads shall have sufficient spacing to avoid surge breakdown.

Information shall be provided as to the power supply source requirements, signal levels, etc., as applicable.

Information shall be provided that when the approved device is enclosed in an assembly, and not readily accessible, that the approval label shall be placed on the exterior of the cabinet for each type of approved device contained therein.

Information shall be provided which states that the final assembler shall provide in the consumer instructions all applicable customer information.

Guidelines & Procedures for Submittal of Information to the ACTA for Inclusion in the Database of Approved Telephone Terminal Equipment

A modular plug or jack shall be provided which complies with TIA-968-A Chapter 6 requirements for dimensions, tolerances and metallic plating.

Automatic Dialers:

The consumer instructions for automatic dialers must contain the following cautionary notice:

WHEN PROGRAMMING EMERGENCY NUMBERS AND(OR) MAKING TEST CALLS TO EMERGENCY NUMBERS:

Remain on the line and briefly explain to the dispatcher the reason for the call.

Perform such activities in the off-peak hours, such as early morning or late evenings.

Toll Restriction and Least Cost Routing Equipment:

The consumer/purchaser/supplier instructions accompanying this equipment and/or software features of systems must contain the following notice:

The software contained in *[insert specific equipment type or features]* to allow user access to the network must be upgraded to recognize newly established network area codes and exchange codes as they are placed into service.

Failure to upgrade the premises systems or peripheral equipment to recognize the new codes as they are established will restrict the customer and the customer's employees from gaining access to the network and to these codes.

Equipment With Direct Inward Dialing (“DID”):

The consumer/purchaser/supplier instructions accompanying the equipment and/or features of systems with direct inward dialing (DID) interfaces, must contain the following:

ALLOWING THIS EQUIPMENT TO BE OPERATED IN SUCH A MANNER AS TO NOT PROVIDE FOR PROPER ANSWER SUPERVISION IS A VIOLATION OF PART 68 OF THE FCC'S RULES

PROPER ANSWER SUPERVISION IS WHEN:

A. This equipment returns answer supervision to the public switched telephone network (PSTN) when DID calls are:

Answered by the called station

Answered by the attendant

Routed to a recorded announcement that can be administered by the customer premises equipment (CPE) user.

Routed to a dial prompt

Guidelines & Procedures for Submittal of Information to the ACTA for Inclusion in the Database of Approved Telephone Terminal Equipment

B. This equipment returns answer supervision on all DID calls forwarded to the PSTN. Permissible exceptions are:

- A call is unanswered
- A busy tone is received
- A reorder tone is received

Equal Access Requirements:

If equipment such as private branch exchanges (PBXs), key systems or customer-owned coin/credit card telephones is sold to a call aggregator, it must be capable of providing the end user equal access to the carrier of the user's choice. The customer instructions for such equipment must contain the following wording:

This equipment is capable of providing users access to interstate providers of operator services through the use of access codes. Modification of this equipment by call aggregators to block access dialing codes is a violation of the Telephone Operator Consumers Act of 1990.

Electrical Safety Advisory:

Parties responsible for equipment requiring AC power should consider including an advisory notice in their customer information suggesting the customer use a surge arrestor. Telephone companies report that electrical surges, typically lightning transients, are very destructive to customer terminal equipment connected to AC power sources. This has been identified as a major nationwide problem.

Equipment With FAX Capability:

The Customer Information for facsimile (FAX) equipment must contain the following wording:

The Telephone Consumer Protection Act of 1991 makes it unlawful for any person to use a computer or other electronic device, including FAX machines, to send any message unless such message clearly contains in a margin at the top or bottom of each transmitted page or on the first page of the transmission, the date and time it is sent and an identification of the business or other entity, or other individual sending the message and the telephone number of the sending machine or such business, other entity, or individual. (The telephone number provided may not be a 900 number or any other number for which charges exceed local or long-distance transmission charges.)

In order to program this information into your FAX machine, you should complete the following steps: [*Insert here instructions for programming the equipment and the required information or the page where it can be found*].

These requirements apply to all FAX machines, and have been extended to all FAX modems manufactured on or after December 13, 1995.

Alarm Dialing Equipment:

Alarm dialing equipment (equipment code "AL") includes dialers associated with fire and intrusion protection systems, medical alert systems, equipment failure notification systems, and similar event reporting systems. The critical nature of such equipment calls for clear installation instructions so that the equipment will operate as intended. In addition, customers must have clear testing instructions in order to verify proper operation after installation.

The customer information requirements for alarm dialing equipment vary depending upon whether the equipment has "Line Seize" capability and whether that capability is provided by a properly installed RJ31X or RJ38X jack or by utilizing a functionally-equivalent arrangement.

Definitions. For the purpose of these customer information requirements, the following definitions are applicable.

Line Seize capability - A feature of some alarm dialing equipment that allows the equipment to disconnect other equipment connected to the same phone line and initiate an event reporting call even when other equipment (telephone, answering system, computer modem, etc.) on the same line is being used.

Functionally Equivalent arrangement - Equipment and wiring that provides Line Seize capability without the use of an RJ31X or RJ38X jack, *i.e.*, it allows the alarm dialing equipment to disconnect other equipment connected to the same phone line and initiate a call even when the other equipment is in use.

Requirements. The customer information accompanying alarm dialing equipment shall include installation instructions, testing instructions, notice (a) below and one additional notice from (b), (c), or (d) below, whichever is applicable.

a) Notice For All Alarm Dialing Equipment

For all alarm dialing equipment, provide a cautionary notice advising that the equipment must be installed according to manufacturer instructions in order to ensure proper operation and must be tested according to manufacturer instructions immediately after installation, and periodically thereafter, in order to verify proper operation. Use words similar to the following:

Caution - To ensure proper operation, this equipment must be installed according to the enclosed installation instructions. To verify that the equipment is operating properly and can successfully report an alarm, this equipment must be tested immediately after installation, and periodically thereafter, according to the enclosed test instructions.

b) Notice for Equipment with Line Seize Capability using an RJ31X or RJ38X Jack

For alarm dialing equipment with Line Seize capability by means of an RJ31X or RJ38X jack, provide a cautionary notice that the RJ31X or RJ38X jack must be installed correctly in order for the Line Seize feature to work properly when other equipment connected to the same line is in use. Use words similar to the following (where RJ38X may be used in place of RJ31X, if appropriate, and the name and/or model number of the equipment may be substituted for the term "alarm dialing equipment" in the text and figure):

Caution - In order for "alarm dialing equipment" to be able to seize the phone line to report an alarm or other event when other customer equipment (telephone, answering system, computer modem, etc.) connected to the same line is in use, "alarm dialing equipment" must be connected to a properly installed RJ31X jack. The RJ31X jack must be connected in series with, and ahead of, all other equipment attached to the same phone line. Series installation of an RJ31X jack is depicted in the figure below. If you have any questions concerning these instructions, you should consult your telephone company or a qualified installer about installing the necessary jack and alarm dialing equipment for you.

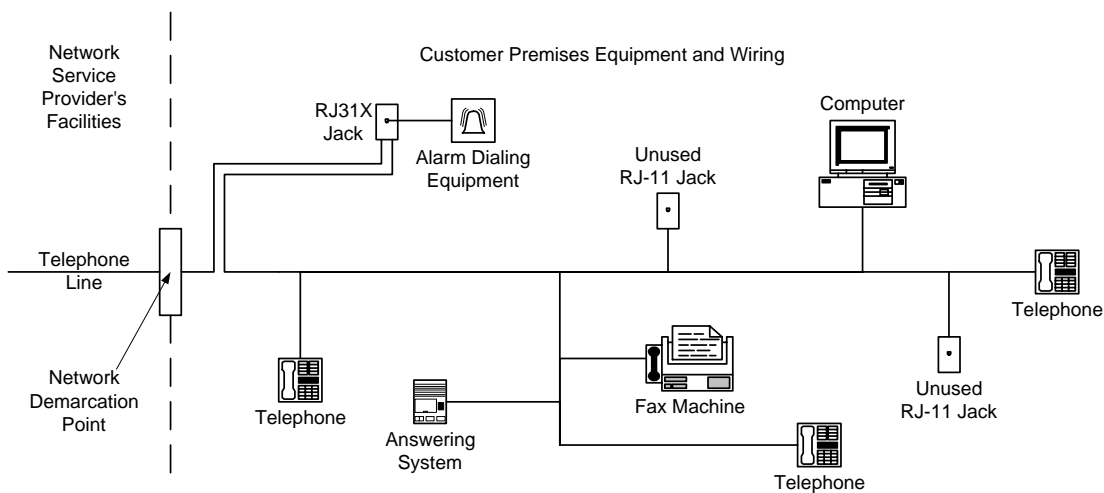

c) Notice for Equipment Utilizing A Functionally Equivalent Arrangement to Provide Line Seize Capability

For alarm dialing equipment that provides Line Seize capability by means of a functionally equivalent arrangement as defined above, provide a cautionary notice that the equipment must be installed according to manufacturer instructions in order for the alarm dialing equipment to work properly when other equipment connected to the same line is in use. Use words similar to the following:

Caution - Verification of Line Seize capability should be made immediately after installation, and periodically thereafter, in order to ensure that this equipment can initiate a call even when other equipment (telephone, answering system, computer modem, etc.) connected to the same line is in use.

d) Notice for Alarm Dialing Equipment without Line Seize Capability

For alarm dialing equipment without Line Seize capability, provide a cautionary notice advising that the equipment is not able to report an alarm when other equipment connected to the same line is in use. Use words similar to the following:

Caution - This equipment cannot report an alarm when other equipment (telephone, answering system, computer modem, etc.) connected to the same phone line is in use.

Type Z Ringer Information

Equipment that has on-hook impedance characteristics that do not conform to the requirements of TIA-968 may be conditionally approved, as long as the other relevant requirements are met and provided that the equipment is labeled with a Ringing Type designation "Z".

"Z" ringer status was created for equipment that normally does not get connected to the network.

Under present technical requirements, any equipment approved with the type Z designation may only be used connected to the network with the consent of the local telephone company. Customer information provided with telephone equipment having a Z ringer designation shall provide the following wording:

CAUTION: this equipment may be connected to the network only be used with the consent of the local telephone company.

---END CONSUMER INFORMATION---

APPENDIX F: TTE Submission Form (Informative)

Administrative Council for Terminal Attachments

c/o ATIS
 1200 G Street, NW Suite 500
 Washington, D.C. 20005



TELEPHONE TERMINAL EQUIPMENT (TTE) SUBMISSION FORM Ver. 1.06

*Please refer to the *Guidelines & Procedures for submittal of information to ACTA for inclusion in the database of approved Telephone Terminal Equipment ("TTE")* for a detailed item description of each field.

NOTE: For SDoC filings only.
Information of external company filing for Responsible Party, if applicable.

1a. Name of Organization Granting Approval

Company Name:				Company Name:			
Address:				Address:			
City:	State:	Zip:	Country:	City:	State:	Zip:	Country:
Submitter's Name:				Submitter's Name:			
Phone Number:				Phone Number:			
Email Address:				Email Address:			
1b. TCB Identification Number (if applicable)				1c. Declaration of Conformity Included? (yes/no)			

2. Terminal Approval Date

3. Product Identifier

--	--

4. Responsible Party

5. U.S. Agent for Service

Company Name:				Company Name:			
Address:				Individual or Department			
City:	State:	Zip:	Country:	Address:			
Responsible Party Point of Contact:				City:	State:	Zip:	
Phone Number:				Phone:			
Email Address:				URL:			

Guidelines & Procedures for Submittal of Information to the ACTA for Inclusion in the Database of Approved Telephone Terminal Equipment

6. Equipment Description

6a. Country Of Origin

--	--

7. Responsible Party Code (RPC)

8. Manufacturer's Code (if available)

--	--

9. Current Authorization Number (only if Modification, Notice, Re-certification, and/or Re-declaration filing)

10. Equipment Code

--	--

11a. List of Brand or Trade Name(s) Including New and Existing Names

11b. List of New and Existing Model Number(s) for Each Brand or Trade Name

12. Network address signaling code

--

13a. AC Ringer Equivalence Number (REN)

13b. Hearing Aid Compatibility (YES/NO/NA)

13c. USOC Jack(s)

13d. Repetitive Dialing to a Single Number (YES/NO)

14. Filing Status

--

15. Facility Interface Code(s)

16. Manufacturer Port ID

--	--

17. Service Order Code(s) (SOC)

18. Answer Supervision Code(s)

--	--

19. Ancillary Equipment

	Certification Status	Trade Name	Model Number	List of Ancillary Equipment by Type	Manufacturer's Identifier
1.					
2.					
3.					
4.					

Guidelines & Procedures for Submittal of Information to the ACTA for Inclusion in the Database of Approved Telephone Terminal Equipment

If you are submitting an original filing or re-certification please fill out the following information. This will give you your ACTA Product-Labeling Number.

ACTA PRODUCT LABEL				
US:				

#7 #10 #13a (leave out the decimal point) #3

- #7. Responsible Party Code (RPC)
- #10. Equipment Code
- #13a. AC Ringer Equivalence Number (REN)
- #3. Product Identifier

APPENDIX G: Responsible Party Code Form (Informative)



Administrative Council for Terminal Attachments

c/o ATIS
 1200 G Street, NW Suite 500
 Washington, D.C. 20005

RESPONSIBLE PARTY CODE (RPC) FORM Ver. 1.0

*Please refer to the *Guidelines & Procedures for submittal of information to ACTA for inclusion in the database of approved Telephone Terminal Equipment ("TTE")* for a detailed item description of the requirements for the request for RPCs, transfers of RPCs, and for additional required documentation.

1a. Name of Company Requesting RPC

1b. Request for Update of RPC Information

Company Name:				Company Name:			
Address:				Address:			
City:	State:	Zip:	Country:	City:	State:	Zip:	Country:
Submitter's Name:				Submitter's Name:			
Phone:				Phone:			
Email:				Email:			
URL:				URL:			

1c. Request for Transfer of RPC

2. Name of Company Filing Request

Company Name:				Company Name:			
Address:				Address:			
City:	State:	Zip:	Country:	City:	State:	Zip:	Country:
Submitter's Name:				Submitter's Name:			
Phone:				Phone:			
Email:				Email:			
URL:							

3. Responsible Party Primary Point of Contact

4. Responsible Party Additional Point of Contact

(Must Be Employee of the Responsible Party)

(May be a third party agent or contact.)

Name:				Name:			
Company Name:				Company Name:			
Address:				Address:			
City:	State:	Zip:	Country:	City:	State:	Zip:	Country:
Phone:				Phone:			
Email:				Email:			

Please note that the Primary Point of Contact and Additional Points of Contact will receive notice of any filing made on behalf of the Responsible Party.

Guidelines & Procedures for Submittal of Information to the ACTA for Inclusion in the Database of Approved Telephone Terminal Equipment

Appendix H: Credit Card Payment Form (INFORMATIVE)

ACTA or FCC Product Number(s): _____

Charges:

Filing Type	Cost Per Filing	Quantity	Cost
Original	\$425		
Modification	\$425		
Notice of Change	\$425		
Request for RPC	\$425		
SDoC Posting	\$425		
Transfer of RPC	\$425		
AOF Corrections	\$95		
Handling Fee	\$95		
Total to be Charged			

Name: _____

Company: _____

Billing Address: _____

City: _____ State: _____ Zip: _____

Phone: _____ Fax: _____

E-mail: _____

Form of Payment:

Circle one:VISA..... MasterCard..... American Express

Card # _____ Exp. Date: _____

V Code _____ (FOR VISA AND MASTERCARD – The V Code is the last 3 digits on the back of the card)

I agree to the charges indicated above and authorize the Alliance for Telecommunications Industry Solutions (ATIS) to charge my credit card the submitted amount. I understand and acknowledge that the inclusion of the information submitted is subject to the receipt of payment in full of all relevant fees.

Signature _____ Date _____

Name as it appears on credit card: _____

**ACTA SECRETARIAT
c/o ATIS
1200 G Street NW, Suite 500
Washington, DC 20005**

Note: Transactions will NOT be processed without a signature. Please keep a copy of this form for your records.